

Geberit - Silent

2006

Australian Catalogue

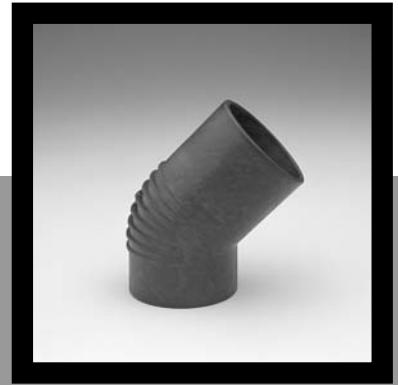

ACOUSTICS AND NOISE CONTROL IN DRAINAGE SYSTEMS

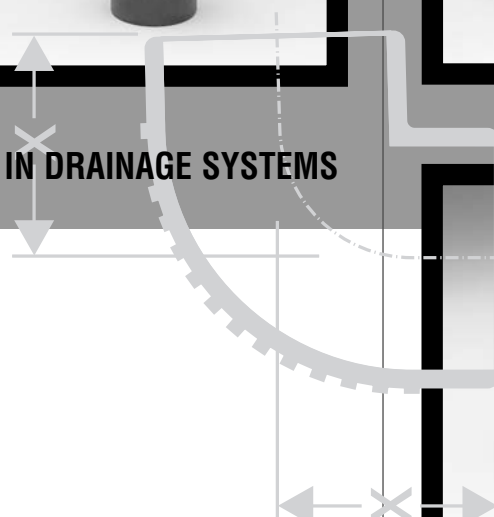

reece[™]
Plumbing Centres

■ **GEBERIT**

Contents	1
General Information	2
Geberit Silent Jointing Methods	3
Geberit Silent Pipes and Fittings	4-9
Installation Techniques	10-15
Installation Instructions	16-19
Technical Specifications	20-21
Material/Standards/Environment Aspect	22
Watermark Licence	23-24

GENERAL INFORMATION ABOUT THE NEW GEBERIT SILENT

The new Geberit Silent product is a drainage system for buildings with increased levels of sound proofing. Its outstanding acoustical insulation properties are achieved by:

- Considerable increased weight.
- Patented material specially developed for this purpose.
- Fittings with ribs for further improvement of sound absorption near impact zones.
- Acoustically insulated pipe brackets to prevent solid-borne sound.

The complete range consists of pipes and fittings with dimensions from \varnothing 56 mm to \varnothing 110 mm. This guarantees complete acoustical insulation from the apparatus connection through to the ground pipe line.

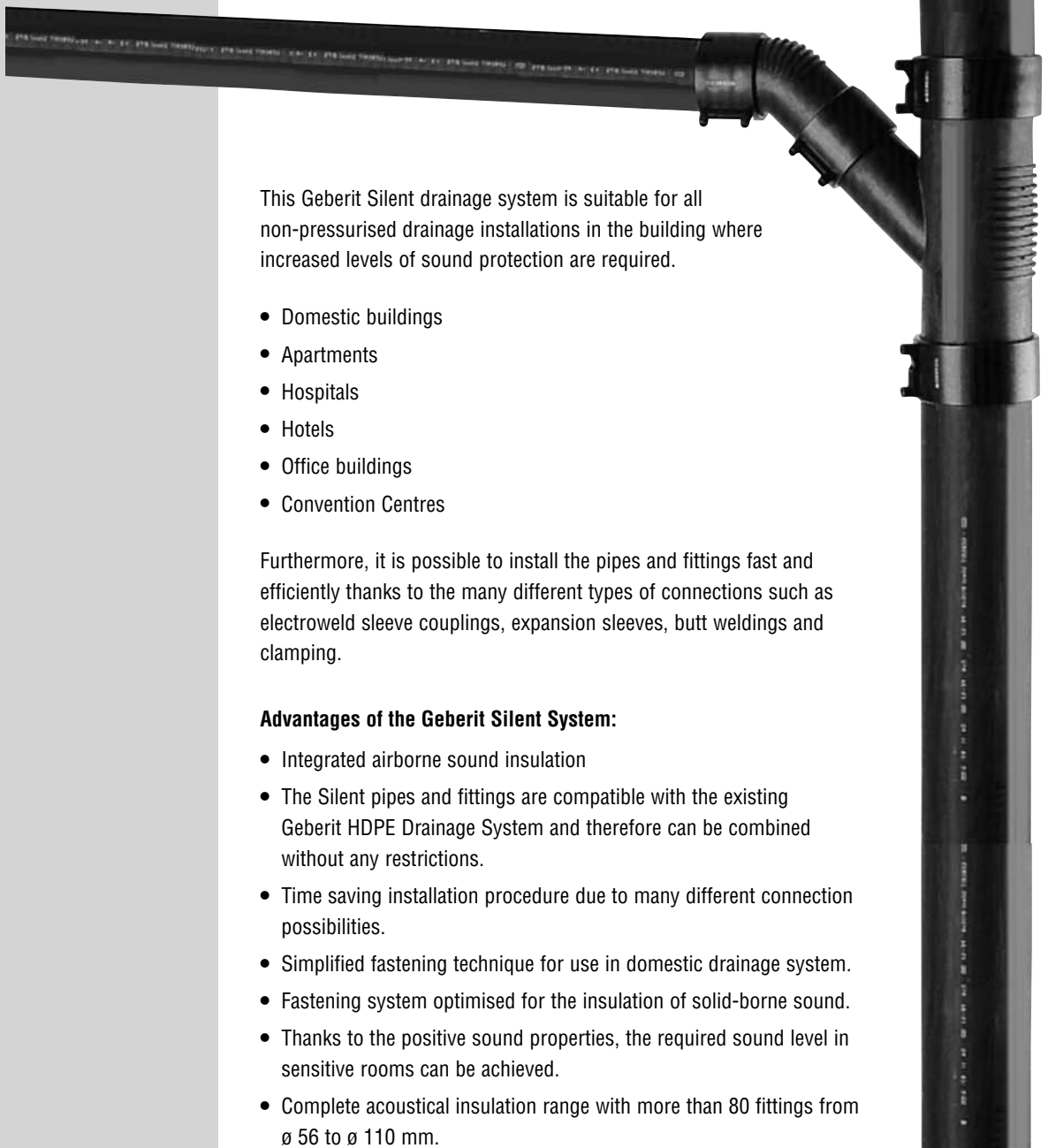

This Geberit Silent drainage system is suitable for all non-pressurised drainage installations in the building where increased levels of sound protection are required.

- Domestic buildings
- Apartments
- Hospitals
- Hotels
- Office buildings
- Convention Centres

Furthermore, it is possible to install the pipes and fittings fast and efficiently thanks to the many different types of connections such as electroweld sleeve couplings, expansion sleeves, butt weldings and clamping.

Advantages of the Geberit Silent System:

- Integrated airborne sound insulation
- The Silent pipes and fittings are compatible with the existing Geberit HDPE Drainage System and therefore can be combined without any restrictions.
- Time saving installation procedure due to many different connection possibilities.
- Simplified fastening technique for use in domestic drainage system.
- Fastening system optimised for the insulation of solid-borne sound.
- Thanks to the positive sound properties, the required sound level in sensitive rooms can be achieved.
- Complete acoustical insulation range with more than 80 fittings from \varnothing 56 to \varnothing 110 mm.

OVERVIEW, JOINTING METHODS

Pipes:

Dimensions \varnothing 56 to 160 mm, compatible with the Geberit HDPE pipes and fittings range, can be joined with electroweld sleeve coupling or butt welding.

Expansion sleeves:

To compensate thermal movement and as an adaptor to other pipe materials.

Couplings:

For fast installation, no special tools required.

Solid-borne sound insulations:

For additional insulation against solid-borne sound.

Butt welds:

Rigid, non removable tension-resistant.

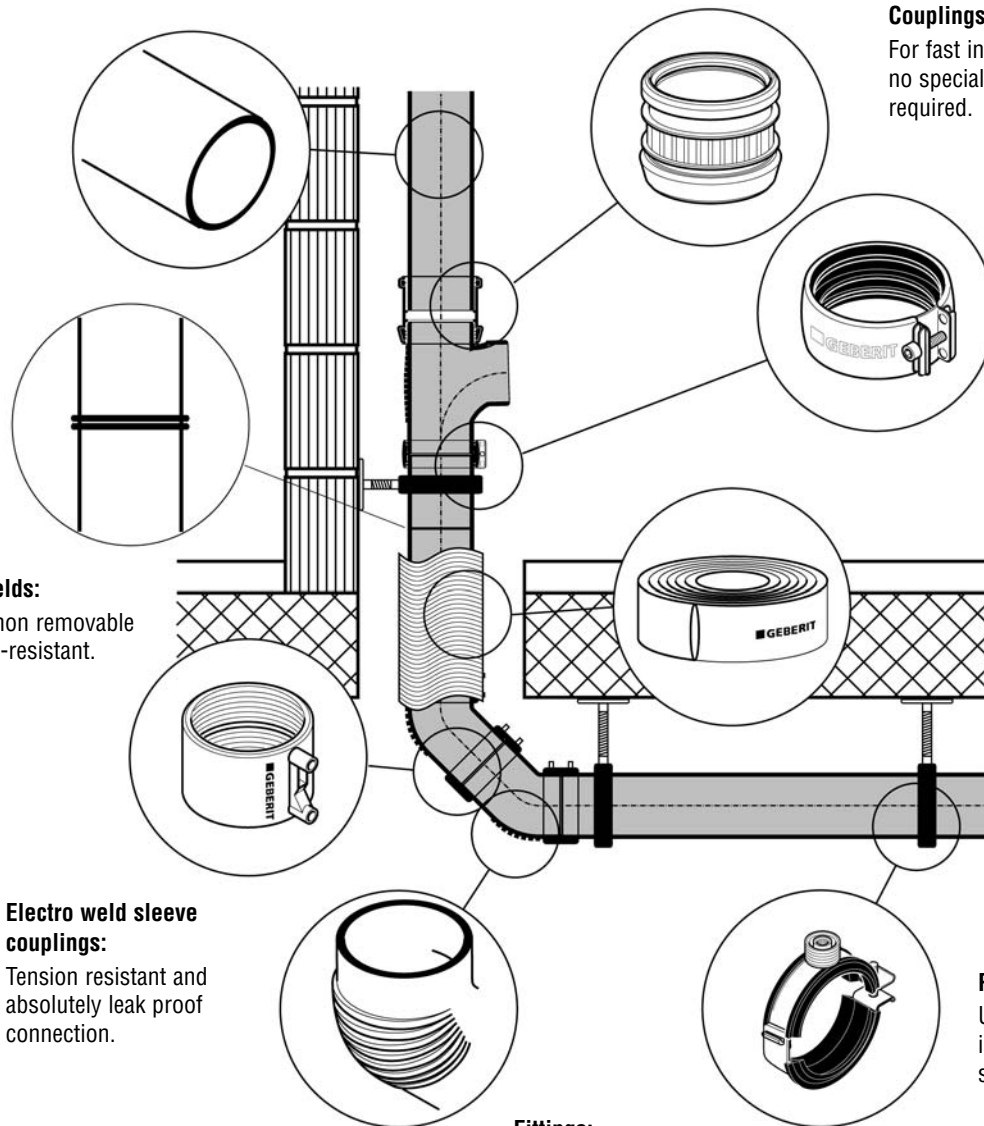

Electroweld sleeve couplings:

Tension resistant and absolutely leak proof connection.

Fittings:

Complete range with additional acoustical insulation ribs in the impact area.

Pipe brackets:

Universal acoustically insulated fastening system.

PIPE AND FITTINGS

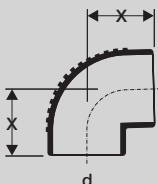
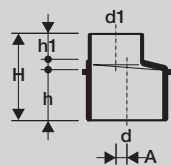
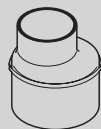
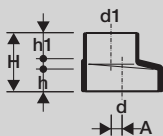
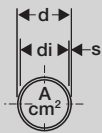
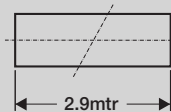
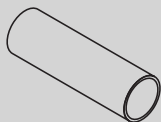

SILENT PIPES

D (mm) (Aust)	s (mm)	di (mm)	A (cm ²)	Art.No	Reece Code
56	3.2	49.6	19.3	305.000.14.2	1433000
63	3.2	56.6	25.1	306.000.14.2	*
75	3.6	67.8	36.1	307.000.14.2	1433002
90	5.5	79	49	308.000.14.2	*
110	6	98	75.4	310.000.14.2	1433004
160	7	146	167.4	315.000.14.2	1433006

*Standard Pipe length is 2.9mtr.

SILENT ECCENTRIC REDUCERS

d (mm)	d1 (mm)	H	h	h1	A	Art.No	Reece Code
63	56	8	3.4	3.7	0.4	306.050.14.1	*
75	56	8	3.3	3.7	0.9	307.050.14.1	1433010
75	63	8	3.3	3.7	0.6	307.060.14.1	1433011
90	56	8	3.1	3.7	1.5	308.050.14.1	*
90	63	8	3.1	3.7	1.1	308.060.14.1	*
90	75	8	3.3	3.7	0.6	308.070.14.1	*

SILENT ECCENTRIC REDUCERS

d (mm)	d1 (mm)	H	h	h1	A	Art.No	Reece Code
110	56	11	6.0	3.7	2.4	310.050.14.1	1433015
110	63	11	6.1	3.7	2.1	310.060.14.1	*
110	75	11	6.0	3.7	1.5	310.070.14.1	1433017
110	90	11	6.1	3.7	1	310.080.14.1	*

SILENT ELBOW 88.5 DEGREE

D	X	Art.No	Reece Code
56	6.5	305.880.14.1	1433052
63	7.0	306.880.14.1	*
75	7.5	307.880.14.1	1433053
90	8.0	308.880.14.1	*
110	9.5	310.880.14.1	1433054

*Pipe and fittings available on request. Conditions may apply. All measurements in cm, unless otherwise indicated.

SILENT BEND 88.5 DEGREE

D	X	K	Art.No	Reece Code
56	11	3.0	305.885.14.1	1433024
63	11.5	2.5	306.885.14.1	*
75	12.8	2.5	307.885.14.1	1433026
90	15.6	4.0	308.885.14.1	*
110	16.9	4.0	310.885.14.1	1433028

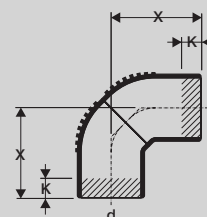
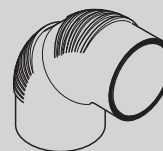

SILENT BEND 60 DEGREE

D	X	K	Art.No	Reece Code
56	9.1	3.5	305.600.14.1	1433030
63	9.7	3	306.600.14.1	*
75	11.3	3.5	307.600.14.1	1433032
90	13.8	4.5	308.600.14.1	*
110	14.6	4.5	310.600.14.1	1433034

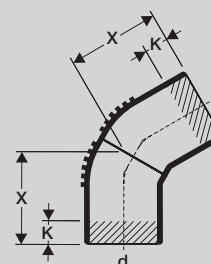
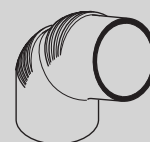

SILENT ELBOWS 45 DEGREE

d	X	X1	K	Art.No	Reece Code
56	7.5	4.5	3	305.450.14.1	1433036
63	7.5	5	2.5	306.450.14.1	*
75	8	5	2.5	307.450.14.1	1433038
90	10	5.5	4	308.450.14.1	*
110	10	6	4	310.450.14.1	1433040

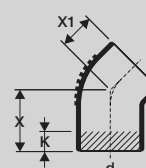

PIPE AND FITTINGS

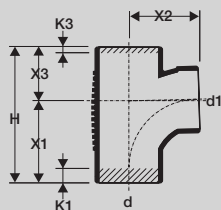
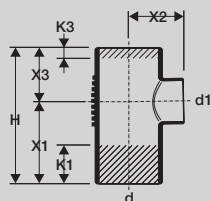
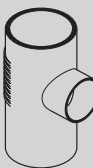
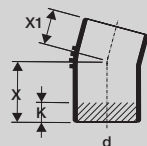
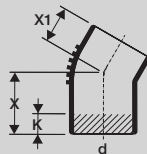

SILENT ELBOWS 30 DEGREE

d	X	X1	K	Art.No	Reece Code
56	7.5	4.5	3.5	305.300.14.1	1433042
63	7.5	5	3	306.300.14.1	*
75	8	5	3.5	307.300.14.1	1433044
90	10	6.5	4.5	308.300.14.1	*
110	10	6	4.5	310.300.14.1	1433046

SILENT ELBOWS 15°

d	X	X1	K	Art.No	Reece Code
56	7.5	4.5	3.5	305.150.14.1	tba
63	7.5	5.0	3.5	306.150.14.1	*
75	8.0	5.0	3.5	307.150.14.1	tba
90	10.0	5.5	5.5	308.150.14.1	*
110	10.0	6.0	5.5	310.150.14.1	tba

SILENT JUNCTION 88.5 DEGREE

d	d1	X1	X2	X3	H	K1	K3	Art.No	Reece Code
56	56	10.5	7	7	17.5	4.5	-	305.058.14.1	*
63	56	10.5	7	7	17.5	4.5	-	306.058.14.1	*
63	63	10.5	7	7	17.5	4	-	306.068.14.1	*
75	56	10.5	7	7.5	18.0	4.5	-	307.058.14.1	1433059
75	63	10.5	7.5	7.5	18.0	4	-	307.068.14.1	*
75	75	10.5	7.5	7.5	18.0	3.5	-	307.078.14.1	1433060
90	56	12	8	8.3	20.3	6	2	308.058.14.1	*
90	63	12	8	8.3	20.3	5.5	1.5	308.068.14.1	*
90	75	12	8	8.3	20.3	5	1	308.078.14.1	*
90	90	12	8.3	8.3	20.3	4.5	-	308.088.14.1	*
110	56	13.5	9	9	22.5	7.5	3	310.058.14.1	1433061
110	63	13.5	9	9	22.5	7	2.5	310.068.14.1	*
110	75	13.5	9	9	22.5	6.5	2	310.078.14.1	*

SILENT SWEEP JUNCTION 88.5 DEGREE

d	d1	X1	X2	X3	H	K1	K3	Art.No	Reece Code
90	90	12.0	10.5	8.3	20.3	1.5	0.5	308.089.14.1	*
110	90	13.5	11.5	9	22.5	4	4	310.088.14.1	*
110	110	13.5	11.5	9	22.5	2.5	-	310.108.14.1	1433068

SILENT JUNCTION 45 DEGREE

d	d1	X1	X2,3	H	K1	Art.No	Reece Code
56	56	6	12	18	1.5	305.054.14.1	1433070
63	56	6.5	13	19.5	2	306.054.14.1	*
63	63	6.5	13	19.5	2	306.064.14.1	*
75	56	7	14	21	3.5	307.054.14.1	*
75	63	7	14	21	3	307.064.14.1	*
75	75	7	14	21	2	307.074.14.1	1433076
90	56	8	16	24	5	308.054.14.1	*
90	63	8	16	24	5	308.064.14.1	*
90	75	8	16	24	4	308.074.14.1	*
90	90	8	16	24	2.5	308.084.14.1	*
110	56	9	18	27	7	310.054.14.1	1433063
110	63	9	18	27	6.5	310.064.14.1	*
110	75	9	18	27	5.5	310.074.14.1	1433062
110	90	9	18	27	4.5	310.084.14.1	*
110	110	9	18	27	3	310.104.14.1	1433084

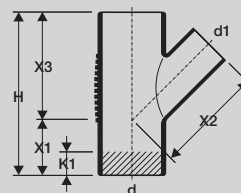
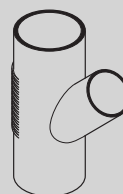

SILENT CORNER BRANCH JUNCTION 88.5 DEGREE

d	d1	X1	X2	X3	H	K1	Art.No	Reece Code
90	90	12	10.5	8.3	20.3	1.5	308.083.14.1	*
110	110	13.5	10	9	22.5	4.5	310.103.14.1	1433086

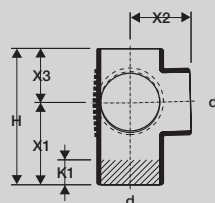
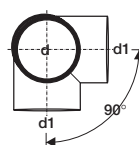
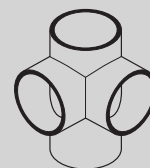

SILENT DOUBLE Y JUNCTION 88.5 DEGREE

d	d1	X1	X2	X3	H	K1	Art.No	Reece Code
90	90	12	10.5	8.3	20.3	1.5	308.082.14.1	*
110	110	13.5	11.5	9	22.5	2.5	310.102.14.1	1433088

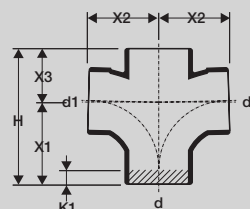
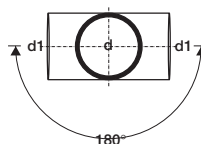
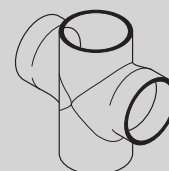

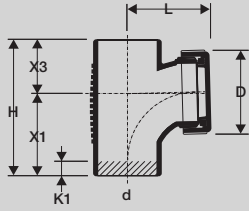
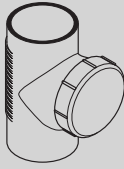

SILENT ACCESS INSPECTION PIPE (27A) 88.5 DEGREE

d	d1	X1	X2	X3	H	K1	Art.No	Reece Code
75	10.5	7	10	17.5	3.5	11.5	307.333.14.1	1433090
110	13.5	9	13	22.5	2.5	14.5	310.333.14.1	1433091

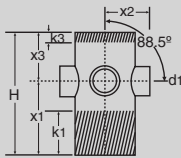
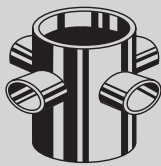

FOUR WAY RISER – FOR FLOOR WASTE GULLIES

Size	Art.No	Reece Code
110/4x56	310.445.14.1	1433114

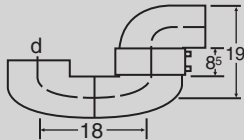
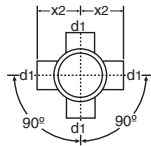

PREFABRICATED TRAP BOTTOM

Size	Art.No	Reece Code
110mm Adjustable Trap Bottom	310.850.14.1	1433116

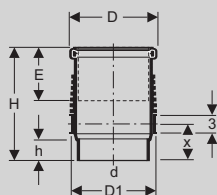

SILENT EXPANSION SOCKET

d	D	D1	H	h	E (20°C)	X	Art.No	Reece Code
75	10	9	19	3.7	6.5	6.2	307.012.14.1	1433094
90	12	11	19	3.4	6.5	6.2	308.012.14.1	*
110	13.5	12.5	19	3.3	6.5	6.2	310.012.14.1	1433096

SILENT EXPANSION SLEEVE

d	D	D1	H	E	E1 (20°C)	X	Art.No	Reece Code
56	8	6.3	10.8	6	3.5	1.3	305.002.14.1	1433100
63	8.7	7.5	10.8	6	3.5	1.3	306.002.14.1	*
75	10	9.0	10.8	6	3.5	1.3	307.002.14.1	1433102
90	11.4	11	11.1	6	3.5	1.6	308.002.14.1	*
110	13.4	12.5	11.1	6	3.5	1.6	310.002.14.1	1433104

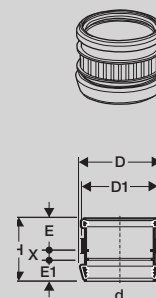

SILENT STAINLESS STEEL COUPLINGS

d	D	H	E	Art.No	Reece Code
56	7.2	5.0	2.3	305.003.14.2	1433106
63	7.9	5.6	2.5	359.429.00.1	*
75	9.1	5.0	2.3	307.003.14.2	1433107
90	10.6	5.0	2.3	308.003.14.2	*
110	12.6	5.0	2.3	310.003.14.2	1433109

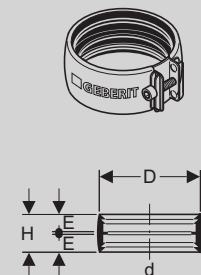

ACOUSTIC CLIPS

Description	Reece Code
Quiet clip 54-58mm	508007
Quiet clip 59-63mm	508008
Quiet clip 64-70mm	508009
Quiet clip 72-78mm	508010
Quiet clip 80-87mm	508014
Quiet clip 87-95mm	508011
Quiet clip 98-104mm	508012
Quiet clip 108-115mm	508013

INSULATION HOSES, 5MM THICK, AGAINST SOLID-BORNE SOUND

d	di	s	Art.No	Reece Code
56/63	8	0.5	306.920.00.1	*
75/90	11.5	0.5	308.920.00.1	*
110	13.5	0.5	310.920.00.1	1433130

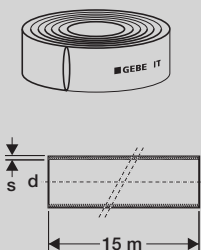

SET OF REPLACEMENT BLADES FOR ALL HAND-OPERATED AND ELECTRIC PLANES FOR SILENT AND HDPE PIPES AND FITTINGS, INCLUDING FIXATION SCREWS

	Art.No	Reece Code
right and left	240.474.00.1	1431586

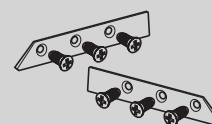

HANDLING THE PRODUCTS

- Same conditions apply as for conventional HDPE pipes and fittings.
- The material is twice as dense as HDPE. The pipes and fittings should only be stored in their original packaging or on the original pallets in order to prevent them undergoing any deformation.
- Avoid storage in a location exposed to direct sunlight. The temperature of the surface of the pipes and fittings should not exceed 40°C. (This rule refers to the construction site storage area shortly prior to installation. This means the mounting temperature is almost identical to the ambient temperature of the installation which is ready to enter service = small amount of thermal contraction of the materials.)

MOUNTING SEQUENCE

CUTTING PIPES AND FITTINGS TO LENGTH

Silent pipes and fittings can be cut to length using standard saws and/or pipe cutters.

Make sure you use a larger cutting wheel when working with pipe cutters.

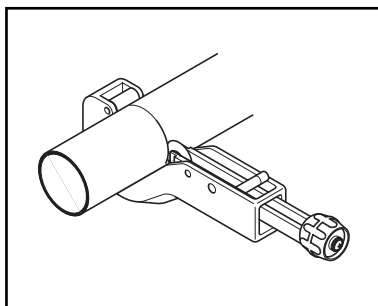

Make sure the cut is at right angles when cutting to length, irrespective of the type of connection.

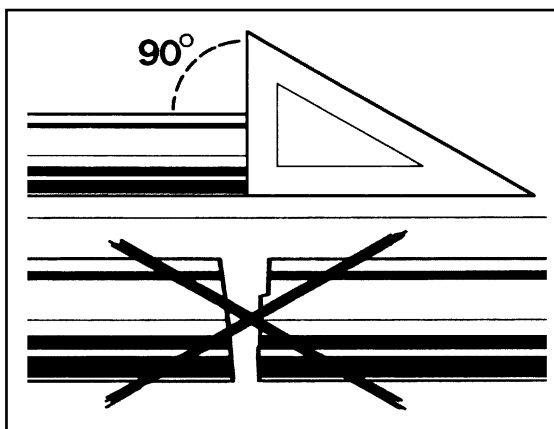

CONNECTION PIPES AND FITTINGS

– WITH ELECTROWELD SLEEVE COUPLINGS

Use a knife to scrape the surfaces of the pipes and fittings in the area where they are to be inserted into the electroweld sleeve coupling, approx. 35mm. Alternatively, you can use abrasive paper with a grain size ≥ 80 .

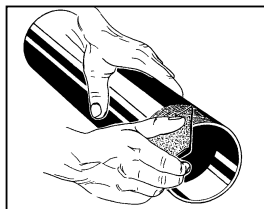

Use a screwdriver to remove the stop ring from the electroweld sleeve coupling if the sleeve is to be slipped over the pipes to be joined.

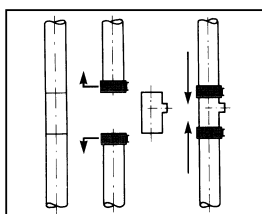
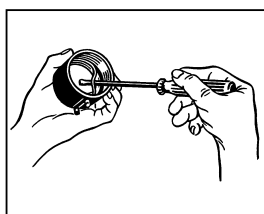

Following this, mark the insertion depth of 30mm in from the ends of the pipe.

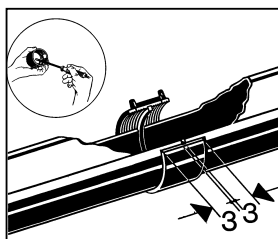

Connect the Geberit electrofusion machine and commence the welding procedure.



- Fix the entire pipeline tension free before the welding procedure.
- Avoid air current through the inside of the pipe during welding.
- Make sure the welding points are clean and dry.

CONNECTION PIPES AND FITTINGS

– WITH SILENT CLAMPS

Make sure the ends of the pipes and/or fittings are clean and free from grease. Loosen the Silent clamp and push it on until the stop ring of the collar makes contact.

Do not chamfer the ends of the pipe!

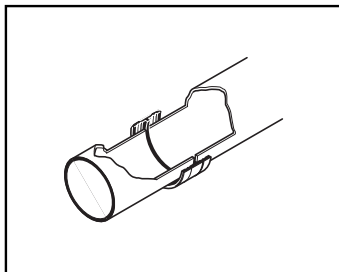

Note:

Make sure that the ends of the pipe in the insertion area are clean and free from grease, and that the surface of the pipe is not damaged.

Cut off any damaged pipe ends.

Use a suitable internal hexagon driver to tighten the Silent clamp screws.

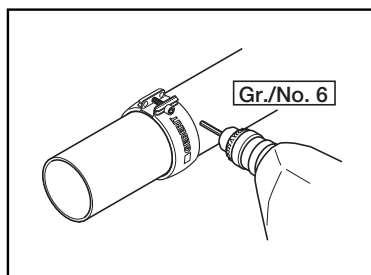

Note:

The insertion depth is only 25mm so it is advisable to mark the pipe ends accordingly in order to ensure that they are fully inserted. Install the pipes so they are not subject to tension. Diversions in the clamp are not allowed.

CONNECTION PIPES AND FITTINGS

– WITH SILENT CONNECTOR SLEEVE

Use a clean, dry cloth to clean the cut ends of the pipes or fittings.

Do not chamfer the pipe ends!

Do not grease! The seals have already been pre-treated with Silicon grease at the factory.

Note:

Make sure that the ends of the pipe in the insertion area are clean and free from grease and that the surface of the pipe is not damaged.

Cut off any damaged pipe ends.

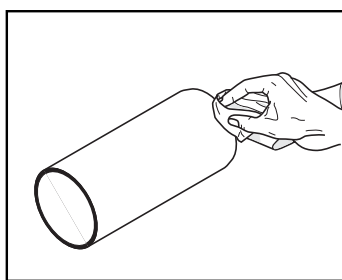

Check the flow directions!

Push the prepared pipe ends all the way into the connector sleeve.

First insert the fixed end up to the stop (overcome the resistance of the claw-type band).

The metal claws hold the socket firmly on the pipe; the socket cannot be removed subsequently!

Then insert the expansion end up to the stop.

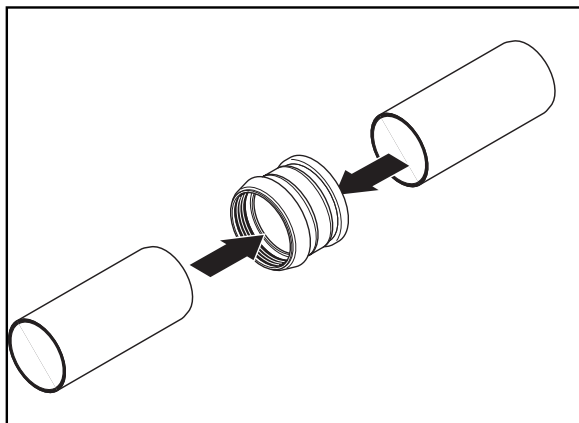

Important:

- Check the lip seals before pushing on!
- Install the pipes so they are not subject to tension.
- Diversions in the socket are not allowed.
- Fix each sleeve with separate anchor bracket.

CONNECTION PIPES AND FITTINGS

– WITH BUTT WELDS

Use Geberit welding machines “Media” or “Universal” for butt-welding. Always comply with the following points:

Only use pipes and fittings with a clean, perpendicular cut.

Always keep the welding plate surfaces clean.

Welding plate temperature 220°C or as indicated by the check-lamp.

Procedure for butt welding:

Clamp the fittings/pipe and plane the ends to the required dimension (by pressing both parts together lightly on the planner) and line them up.

Important: Always use carbide blades for the planning tool (Art.No. 240.474.00.1).

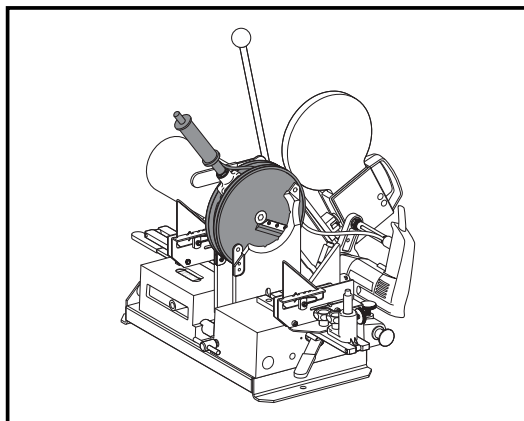

Heat up the parts to be connected. First swivel in the welding plate and press both parts against it lightly. Then hold them without applying further pressure to allow the heat to flow evenly into the ends of the pipe during this period.

Refer to table for guidance values of heating time.

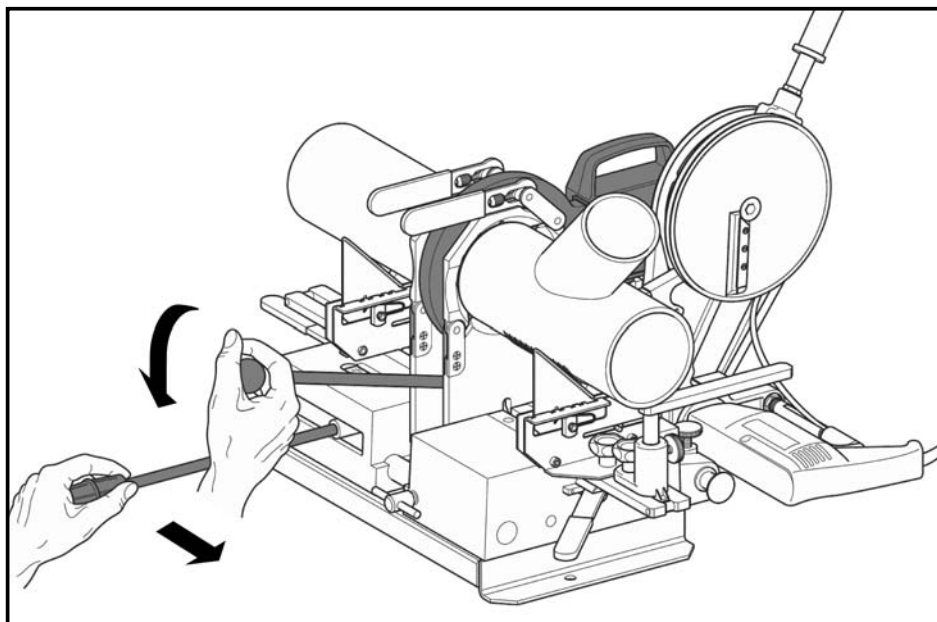

Welding together:

Swivel out the welding plate and bring the pipes/fittings together immediately. Continuously increase the welding pressure within the prescribed time to the required value (\emptyset scale on the machine).

Then lock-in position using the holder.

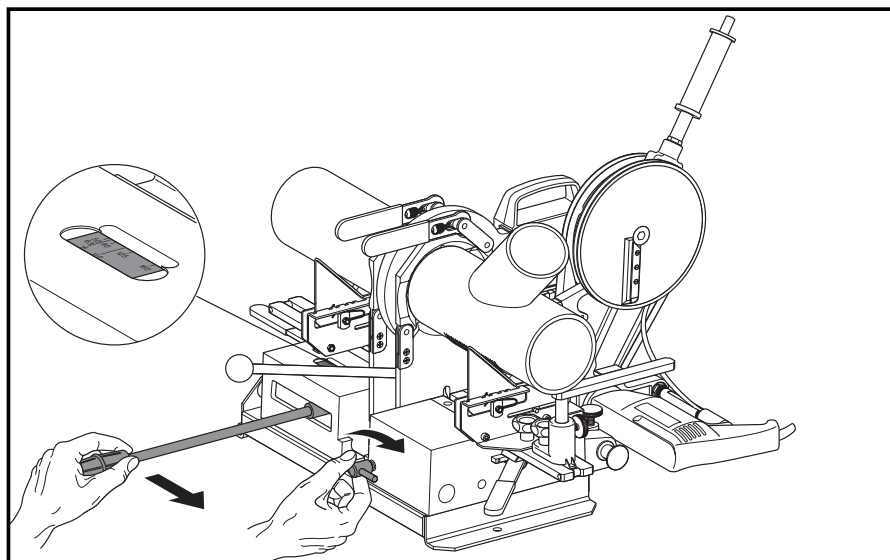

You can release the holder after the indicated welding/cooling time. Unclamp the welded parts.

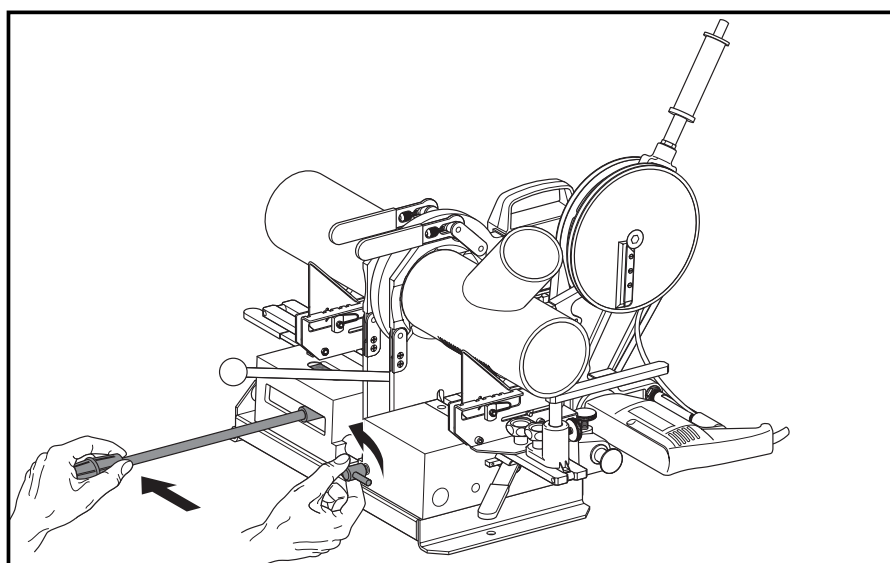

GUIDANCE VALUES FOR BUTT-WELDING:

Silent Pipe/ fitting \emptyset	Welding allowance per weld	Heating- up time	Time to complete pressure build-up	Welding and cooling time	Welding pressure (as for HDPE; scale on the machine)
56mm	0.3cm	45 sec	4 sec	3 min	80 N
63mm	0.3cm	45 sec	4 sec	3 min	90 N
75mm	0.4cm	50 sec	4 sec	4 min	100 N
90mm	0.5cm	70 sec	5 sec	5 min	150 N
110mm	0.6cm	85 sec	5 sec	5 min	220 N
160mm	0.7cm	100 sec	5 sec	5 min	450 N

GEBERIT SILENT

INSTALLATION INSTRUCTIONS

Thermal expansion and contraction also has to be considered and compensated for in Geberit Silent pipes.

In contrast to the HDPE range where it is necessary to deal with more extreme values, it is possible to assume lower values for acoustically insulated domestic drainage systems. Consequently, the installation instructions can be simplified.

As a result, there is no rigid assembly when using Geberit Silent pipes and fittings! This is particularly important for acoustical reasons.

The change in length is absorbed by expansion sockets, expansion sleeves and bending legs.

VERTICAL INSTALLATION OF DOWNPIPES

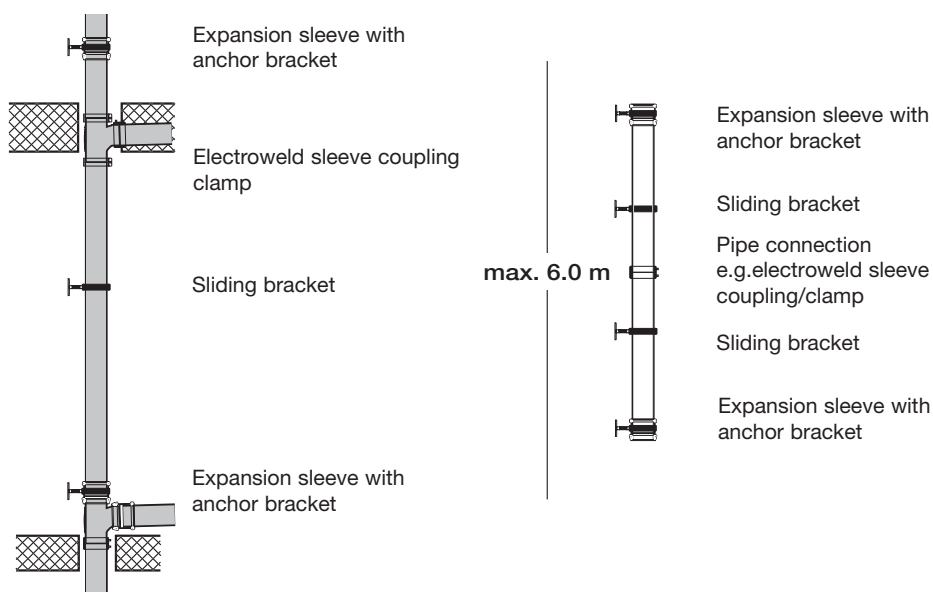

Always fit a Silent connector sleeve in the down pipe at each floor. This applies irrespective of whether or not any connections are enclosed in concrete. The anchor bracket is attached directly to the expansion sleeve.

In the case of down pipes which do not run through storeys, such as rainwater pipes or where no connection pipes are connected, utilise a Silent expansion sleeve at least every 2 pipe lengths (6 m').

GUIDE BRACKETS IN VERTICAL PIPES

The maximum pipe bracket spacing for Geberit Silent pipes is the same as for HDPE pipes.

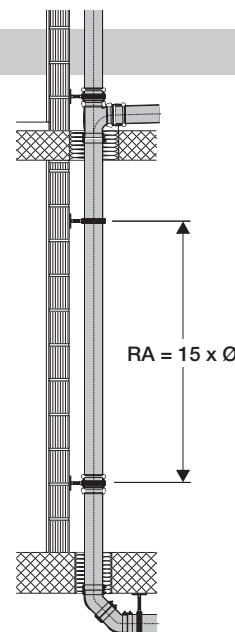

INSTALLING HORIZONTAL CONNECTION PIPES AND LOOPS

Horizontal connection pipes and loops should always be laid in acoustically treated spaces and must be decoupled from the structure to prevent solid-borne sound from propagating.

HORIZONTAL CONNECTION PIPE / LOOP WITH DEFLECTION LEG

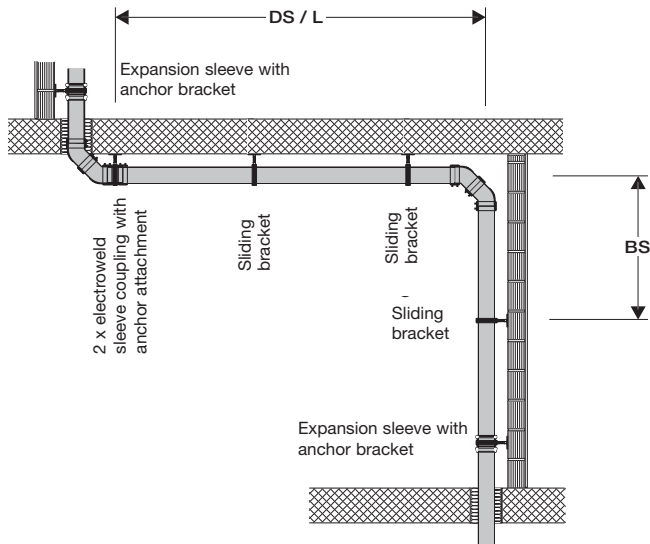

The expansion of pipe DS is absorbed by the deflection leg BS. Anchor brackets and sliding brackets must be arranged accordingly for this. Only electroweld sleeve couplings or butt welds shall be used for the connections.

HORIZONTAL CONNECTION PIPE / LOOP WITH SILENT CONNECTOR SLEEVES

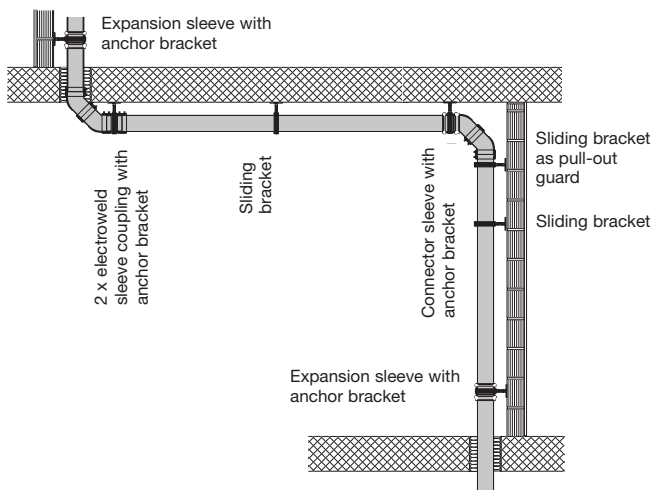

The expansion is absorbed in the expansion side of the expansion sleeve. Anchor brackets and sliding brackets must be arranged accordingly. Clamps may also be used for the connections.

Important:

A suitable guide bracket must be used for securing the pipe in the case of diversions immediately after a Silent connector sleeve (both horizontal and vertical) to prevent the pipe from being pulled out of the fixed side of the socket!

SPACING FOR BRACKETS

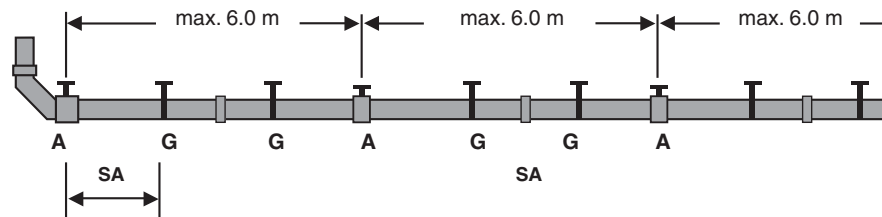

A = Anchor bracket G = Guide bracket

Pipe Diameter [mm]	Spacing SA Horizontal [m]	Spacing SA Vertical [m]	Weight FG Horizontal (filled pipe, incl. Safety factor)	Weight FG Vertical (filled pipe, incl. Safety factor)
Ø 56	0.55	1.5	25 N	125 N
Ø 63	0.65	1.5	35 N	155 N
Ø 75	0.75	1.5	55 N	220 N
Ø 90	0.90	1.5	105 N	304 N
Ø 110	1.10	1.65	180 N	485 N
Ø 160	1.60	2.4	350 N	980 N

Important: Use always sound insulated pipe clamps.

WALRAVEN BIFIX 5000 SLIDE CLAMPS

BIFIX 5000

Two-part Clamp: 2 locking screws, one side with WM quick locking system and spacer washers between the flanges

Specific Characteristics

- WM quick locking system for fast and secure fixing (for vertical pipes keep open side of the slot down)
- noise insulation according to DIN 4109
- rubber lining especially developed for application to plastic pipes
- inner part of rubber lining is flush to improve sliding of pipe in clamp
- ageing resistant EPDM rubber lining
- removable spacer washers between the flanges, making the clamp suitable for either location or tight fixing

Technical Characteristics

- made of steel 1.0332
- zinc plated
- locking screws: combi slot cheese head screw DIN-EN-ISO 7045 (DIN 7985), zinc plated
- resistance welded connecting nut M8, H = 8 mm; M10, H = 10 mm
- EPDM rubber lining without plasticizer (in consequence very suitable for plastic pipes), colour green, flush inner part

BIFIX 5000

Reece Code	d (mm)	Pipe Fit (Ø x mm)	G (Ø)	S (ØxL)	B x s (mm)	safe load (N)
510212	38-43	40geb	M10	M6 x 25	20 x 1,25	1090
510203	56-58	56geb	M10	M6 x 25	20 x 2,0	1470
510215	64-67	63geb	M10	M6 x 25	20 x 2,0	1470
510204	70-76	75geb	M10	M6 x 25	20 x 2,0	1470
510205	86-91	90geb	M10	M6 x 25	20 x 2,0	1470
510206	110-114	110geb	M10	M6 x 25	20 x 2,0	1470
510208	155-160	160geb	M10	M6 x 25	20 x 2,0	1470

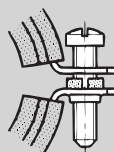
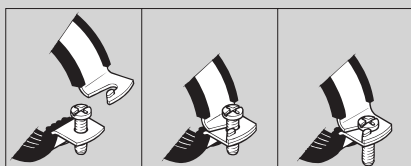

with spacer washer for location only



without spacer washer for tight fixing

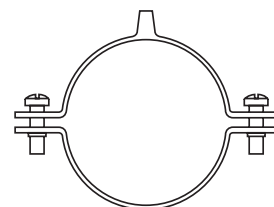

Bolted Clip with 10mm Nut

INSTALLING CONNECTION AND BRANCH PIPES

When **connection and branch pipes are laid in concrete**, the solid-borne sound insulation material compensates for changes in length. Condition: all connections must be tension-resistant and made using electroweld sleeve couplings / butt welds.

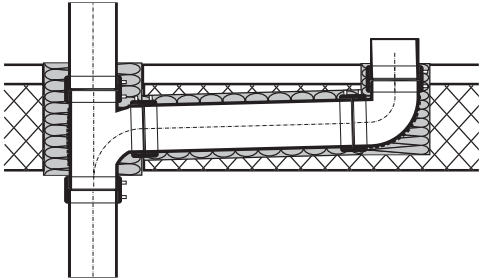

Furthermore, the following measures must be taken in order to achieve optimum acoustic protection:

- Any concrete covering must be at least 4 cm thick.

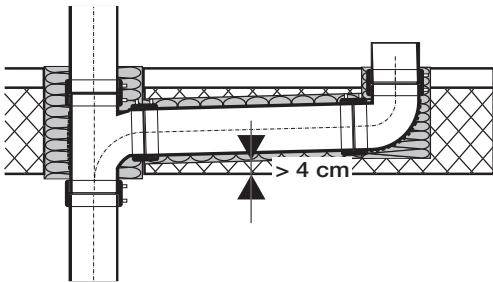

- Avoid intersections with water or heating pipes or electrical pipes. These can increase the sound levels by 3 - 10 dB(A) depending on the situation in the building.

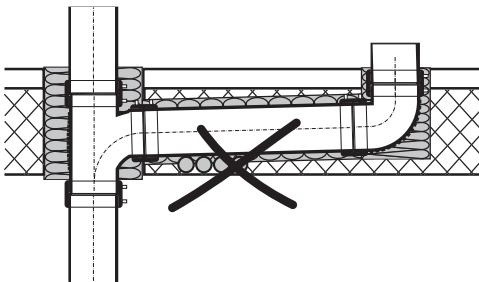

When **connection pipes are in the PreWall**, e.g. GIS walls, install an anchored Silent expansion sleeve every 6 m'. Connections onto this pipe as well as joints in the connector pipe can be made using clamps or Silent expansion sleeves.

Penetrations through these PreWalls must always be decoupled using suitable insulating material! (E.g. tape or hoses against solid-borne sound)

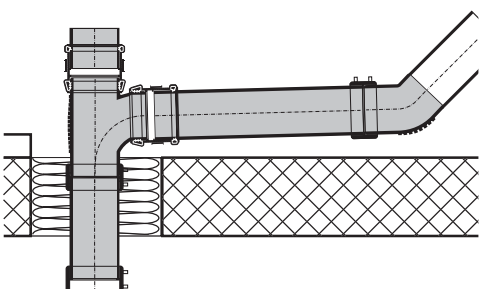

CHEMICAL AND IMPACT RESISTANCE

Overview of the technical specification of Geberit Silent pipes

Name	Unit						
Pipe dimension	mm	56	63	75	90	110	160
Internal diameter	mm	49.6	56.6	67.8	79	98	146
Pipe weight	kg/m'	0.90	1.02	1.37	2.48	3.33	5.72
Water volume	l/m'	1.93	2.51	3.60	4.90	7.54	11.87
Weight of pipe with water	kg/m'	2.83	3.53	4.97	7.38	10.87	17.6
Length of pipe	m	2.90					
Expansion	mm/mK	0.17					
Density	kg/m ³	1700					
Thermal conductivity	W/mK	0.43					
Heat contraction	mm/m'	< 10					
Fire code number/class		4.3 (CH) / B.2 (D)					

CHEMICAL RESISTANCE

The chemical resistance of Silent pipes, fittings and connections is assured against effluent present in domestic drainage systems.

IMPACT RESISTANCE

RESISTANCE TO AGEING

The possible long-term load-bearing capability of a drain material is dependent on the mechanical, thermal and chemical load, on the resistance of the material, the wall thickness and flawless fabrication.

The most important criterion in this regard is the property of the material used.

The service life of Silent pipes is practically unrestricted under the usual conditions of domestic drainage systems.

MATERIAL PROPERTIES

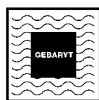

Density 1.7 kg/dm³

This means the material is in the hard quality class and is characterised by increased strength properties.

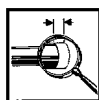

Heat reversion factor max. 10 mm/m'



Resistance to cold

The pipes may freeze as result of their elasticity; however, they are restored to fully intact condition after thawing.



Flexibility

Extremely high flexibility. Nevertheless, take appropriate precautions at expansion joints.

CHEMICAL AND IMPACT RESISTANCE



Melt-flow index 0.4 - 0.8 g/min.

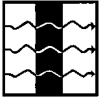

Thermal conductivity 0.43 W/m • K

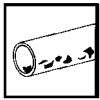

Resistance to abrasion

Very high resistance to abrasion; additional security due to the thick walls.



Thermal expansion 0.17 mm/ m • k

Same as HDPE; per pipe (3 m) = 25 mm given the permitted temperature differentials of 40°C in domestic drainage systems. A negligible amount provided Geberit Silent expansion sleeves are used.



Resistance to hot water

Adequate for the sustained/intermittent maximum temperatures of approx. 60°C experienced in domestic drainage systems.



Impact strength

Unbreakable when used in domestic drainage systems.

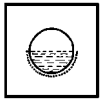

Condensate

No condensate is to be expected in the domestic drainage system as a result of the material's poor thermal conductivity and its considerable wall thickness.



Behaviour in fire

Silent pipes and fittings are flammable.



Leak-tightness

Guaranteed by all connection elements.

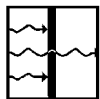

Effect of sunlight

Protected against ageing and embrittlement due to UV radiation by the admixture of approx. 2% soot. Nevertheless, do not store Silent pipes and fittings exposed to sunlight.



Not electrically conductive



Sound

Excellent insulation against airborne sound. However, solid-borne sound must be cushioned by taking appropriate measures (acoustically insulated pipe brackets, insulating material).

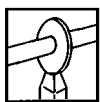

Welding temperature

Identical welding temperature to HDPE; i.e. 220°C.

MATERIAL / STANDARDS / ENVIRONMENTAL ASPECT

MATERIAL / MATERIAL NAME

The material used for these new externally compatible Geberit Silent pipes and Geberit Silent fittings is referred to as PE-S2 (mineral-reinforced HDPE). This compound is an independent development by Geberit and is manufactured by authorised compounders.

The pipes are manufactured by Deriplast. The fittings are produced at the Jona plant.

PIPES AND FITTINGS

Compound:	GEBARYT 961017
Basic material:	PE 80
Volume index MVR 190/5	0.6 +/-02 gr/10 min.
Density:	1.7
Stabilisation OIT 210 °C:	>=25 min.
Colour:	Black

TEST REPORTS / APPROVALS / STANDARDS

This acoustically insulated domestic drainage system was developed with regard to the following standards and directives:

- Acoustical insulation; with reference to DIN 4109, SIA 181, Ö-Norm B-8115, VDI 4100
- Hydraulics; DIN 1986, SN 592000, SN 595012
- Fire protection; DIN 4102

APPROVALS / EXTERNAL SUPERVISION

The application for approval is via the SKZ and the Zurich testing office.

Existing approvals:	DIBT	(D)	Z-42.1-265
	SSIV	(CH)	21011
	QAS	(AUS)	Lic W209 & W612

External supervision is carried out by SKZ in Würzburg (Hydraulics).

ENVIRONMENTAL ASPECT

The compound developed by Geberit is a mineral-reinforced HDPE. Both the carrier material (polyethylene) and the filler (mineral) can be classified as completely without risk from an environmental point of view.

ECOLOGICAL BALANCE SHEET

The ecological balance sheet evaluates the materials and energy aspects over the entire product life-cycle and provides information about the principle pollution arising due to products. When products made from different materials are compared, it shows how high the pollution levels of the various products are. This does not just apply to disposal. The comparison also takes account of:

- Raw material manufacture
- Product manufacture
- Disposal

The study is intended to allow ecologically aware users to base any comparisons on reliable data.



global-mark

Certificate of Approval

This certificate confirms that the company below complies with the following standard:

<i>Company Name</i>	Geberit Pty Ltd
<i>Company Other Name</i>	
<i>Client ID</i>	100150
<i>Certification Standard</i>	MP 52 Spec 005
<i>Scope of Certification</i>	Sanitary plumbing pipes and pipe fittings - Transfer from WaterMark licences WMK00612 and 00209 New WaterMark licence number WMK4001
<i>Type of Certification</i>	Product Certification
<i>Accreditation Status</i>	JAS-ANZ

Certificate Dates:

<i>Certification Review Date</i>	6th December 2005
<i>Certification Expiry Date</i>	8 December 2007
<i>Certificate Issue Date</i>	6th December 2005
<i>Certificate Last Update Date</i>	6th December 2005

Company/Site Address(es):

Suite 7, Level 2, North Tower, 1-5 Railway Street, Chatswood NSW 2067 Australia

The use of the Accreditation Mark indicates accreditation by the Joint Accreditation System of Australia and New Zealand in respect to those activities covered by JAS-ANZ accreditation. Refer to www.jas-anz.com.au/register for verification.

This certification remains valid until the above mentioned expiry date and subject to the organisation's continued compliance with the certification standard, and Global-Mark's Terms and Conditions.

This Certificate of Approval remains the property of Global-Mark Pty Ltd, Company Number: ACN.108-087-654.



Confirm the status and validity of this certificate on: www.global-mark.com.au



trust-mark.com



Plumbing Centres

Product Code: 2130401



